

## EDUCATING ENGINEERS IN RISK CONCEPTS

Graham Schleyer<sup>1</sup>, Rui Fang Duan<sup>1</sup>, Nicola Stacey<sup>2</sup> and Julian Williamson<sup>2</sup>

<sup>1</sup>University of Liverpool, United Kingdom

<sup>2</sup>Health & Safety Laboratory, United Kingdom

### INTRODUCTION

There is increasing recognition, within the UK Health and Safety Executive (HSE) and professional bodies, of the need to educate engineering undergraduates in aspects of risk relevant to their degree(1). However, across degree courses in the UK, the extent and content of risk education varies, and there is potential for it to not always be proportional to the level of risk that undergraduates could be responsible for managing in their professional working life, Lee(2). To address this, the Health and Safety Laboratory (HSL) in collaboration with the University of Liverpool have set up a project to incorporate risk education into the curriculum of an undergraduate engineering degree course. This approach can then be promoted to other educational institutions on the basis of its successful implementation. Integrating risk education into the curriculum has involved defining risk education as a set of learning outcomes, and designing a tool to ascertain students' awareness of risk issues and key concepts. Teaching materials are being developed that use real accident case studies, student interaction and role-play exercises to enhance students' understanding of the concepts of hazard and risk, Schleyer *et al*(3).

The EU strategy on health and safety also identifies education and training as key factors to prevent accidents among young people when they first enter the workplace. An EU project to mainstream occupational health and safety into education(4) was started in 2002. The philosophy of the project is that the sooner children and young people get acquainted with the concepts of health and safety then the sooner they can develop risk awareness, and the better equipped to develop their own framework of learning in their future education. The EU project underpins the goals of the current higher education project on risk awareness.

### RISK AWARENESS EVALUATION

A questionnaire was developed to ascertain students' level of understanding of the risk education learning outcomes prior to receiving formal tuition at undergraduate level. Therefore, the questions were designed to assess understanding of concepts as opposed to knowledge of facts relating to a taught course. The key concepts for each learning outcome were first agreed by the project team. A total of fifty multiple-choice questions were developed to provide some indication of students' knowledge and understanding of the key concepts of the learning outcomes in the following risk topic areas:

- i. Concepts of hazard, safety and risk as part of everyday life (12 questions),
- ii. Engineer's professional responsibilities (12 questions),
- iii. Principles of hazard identification and risk assessment (8 questions),
- iv. Techniques for reducing and controlling risk (6 questions),
- v. Potential exposure to hazards and risk in the workplace (6 questions), and
- vi. Underlying causes of accidents and failures (6 questions).

Due to the time constraints there was no formal testing of the validity of the questionnaire, though there was a limited piloting, resulting in non-substantial changes. The face validity of the questionnaire was judged to be appropriate according to the experience and knowledge of the project team.

A multiple-choice style of question format was adopted to reduce the subjective element of marking a large number of open-ended answers, and to better facilitate comparisons between levels of understanding across the various risk topic areas. Each question had a possible five answers from which the student had to mark one choice that was in their

opinion the best or correct answer. A few questions had a number of potentially valid answers, though the 'correct' answers were based on the preferred set of responses defined by the project team.

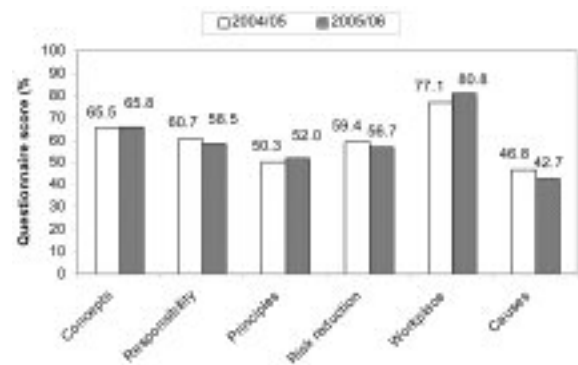
A cohort of new entrants completed this questionnaire at the start, and the end of the 2004/05 academic year. There was a small overall improvement in these scores at the end of the year that was statistically significant. When these end-of-year scores were compared with students overall end-of-year examination scores, there was found to be no relationship. This suggests that the students were receiving little formal tuition in 'risk education' (as identified within the learning outcomes). It also suggests that any improvement in scores between the risk questionnaire at the start, and end of the year, was due to practice effects, and a general learning effect.

The questionnaire was delivered to the new 2005/06 students via the on-line virtual interactive teaching and learning system at Liverpool. The format of the questions was unaltered. A larger number of candidates (211) took part due the enlarged class, which included civil engineering students as well as mechanical, aerospace and integrated. The overall average score was virtually unchanged compared to the 2004/05 results.

## Results

A comparison between the 2004/5 and 2005/6 average scores in each section is given in **figure 1** and shows consistency from year to year across the range of topics. The data from these tests will enable specific areas to be targeted in which the students performed less well than expected or showed a lack of appreciation in a particular topic as highlighted by a poorly scoring question. It was reassuring to know that students appreciated the most safety in the workplace. On the other hand, accident causation was the least understood.

A T-test was conducted to compare last year's scores with this year's scores at the beginning of the academic year. This gave a very high correlation of the scores (0.98), at a 95% confidence level. Thus it is 95% certain that



**Figure 1: Comparison of average scores by section**

there is no significant difference between the groups' scores. This gives a strong basis for proceeding with using the class test to evaluate the success of the new syllabus in achieving the desired learning outcomes relating to risk concepts.

## Key question

In addition to the 50 multiple-choice questions in the 2005/06 evaluation, an essay type question was set at the end. The students were asked to convey why engineering is regarded as a safety critical profession. Most recognised that faulty products put the public at risk of injury or death and that as engineers they therefore had a responsibility to ensure safety was properly considered during design. Many recognised that engineering decisions have a wide impact on everyone. Only a few mentioned their responsibility for their own safety and that of their colleagues. The most succinct answer was: 'People count on engineers to deliver'.

## RISK EDUCATION SYLLABUS

The following topics were proposed as an outline template for a risk education syllabus in an undergraduate engineering programme.

### i. Basic introduction

Aims and objectives (including expected student input and assessment). Definitions and terminology. Engineering as a 'safety-critical' profession. Hazard and risk as part of everyday life. Fundamental concepts of safety,

hazard, likelihood, probability and risk. Bibliography (including web sites).

### **ii. Management of personal risk**

How to control risks associated with the main hazards that a student is likely to come across during lab/project work and later in the workplace. Use of personal protective equipment and emergency procedures.

### **iii. Risk modelling and quantification**

Hazard identification and preliminary hazard analysis. Treatment of uncertainties. Qualitative and quantitative risk assessment. Limitations and potential pitfalls of risk assessment. Failure modes and effects analysis. Fault and event trees. Human error. Assessing the consequences of a specified hazard. Acceptability and tolerability of risk. Cost benefit analysis.

### **iv. Professional responsibilities including legal requirements**

Legal framework. The Health and Safety at Work Act etc 1974. UK regulations and European directives. Legislation enforcement. Prescriptive versus goal setting philosophy. Professional engineering codes of conduct.

### **v. Management of risk**

Safety culture and climate. Safety management systems.

### **vi. Safety in the design process**

Human and organisational factors including basic ergonomics and human error. Inherently safe design. Attitude to safer design. Use of best practice and standards. Case studies.

### **vii. Risk reduction and control**

Prevention. Mitigation and control strategies.

Risk topics have been successfully embedded in some year 1 core engineering modules at the University of Liverpool, through formal lectures, a virtual laboratory exercise and keynote lectures on professional practice. The lectures and lab are complementary with the lab promoting experiential role-play learning. The keynote lectures on professional practice will cover leadership, ethics, inherent safety, human factors and the role of standards.

The plan is to introduce the application of risk assessment techniques into design projects,

group design projects and final year projects in years 2, 3 and 4. Staff will also be encouraged to introduce more forensic analysis type final year projects in the future to enable some students to study certain risk topics in more depth in their final year.

### **Case studies**

While retaining the engineering science theme, it was possible to link several of the key risk concepts to stress analysis through case studies of engineering disasters in one of the engineering mechanics modules. The case studies are used to show what can happen when engineers get it wrong, make mistakes or even worse ignore the warning signs that something is wrong. Two BBC Disaster Series films, the Challenger Space Shuttle and Piper Alpha, are being used in the lectures as showcase examples of how wrong decisions can lead to disaster. This gets students thinking outside the confines of the theory to real issues that could affect them in their future professional life. Shortly after giving the first lecture and showing the Challenger film, an article appeared in the Daily Telegraph reporting the issues surrounding the aerospace engineer who raised safety fears on the A380 Airbus. The direct link between this and the Challenger film was made in the second lecture as a follow-up to emphasise the point that as professional engineers they could face similar issues in their work. This demonstrated the value of including breaking news in the lectures. Safety issues are embedded in the lecture material and integrated with the theory rather than added on as a separate topic. New PowerPoint slides have been produced to enhance the presentation and enable the material to be reviewed on the University's virtual interactive teaching and learning (VITAL) system.

### **Virtual lab**

A new virtual laboratory exercise has been designed based on the Port Ramsgate accident investigation. The development of this drew upon a similar exercise run by the University of Sheffield. The aim of this lab is to learn about the accident investigation process and to appreciate what important lessons can

be learned from engineering failures, that accidents generally have no single cause. The lab will serve to emphasise that human error has a large part to play in the underlying cause of accidents. In this lab, students take on the role of the accident investigation team gathering evidence and data eventually to be used in the criminal prosecution of those parties responsible for the accident. A reconstruction of the scene has been created with a 1/100th scale model that was used in the actual court prosecution and a file of data comprising photographs, witness statements and other technical documents mainly taken from the accident investigation report (5). All year 1 students take the lab exercise in the 1st semester. The lab is carried out in small tutor groups of around 6 to 10 students.

The technical investigation is divided into 5 stages and will be tackled by a different group of students each week. Each group draws on findings from the previous group, as would be done in real life investigations. The lecture material is also timed to synchronise with the particular stage in the investigation. The last two lectures in the 1st semester cover points from the whole investigation to allow every student to appreciate how all the stages are connected.

The stages are:

- i. Recording the incident
- ii. Design considerations
- iii. Risk management
- iv. Materials assessment
- v. Stress analysis

A worksheet has been prepared for each stage to guide the students through the tasks and lead them to record the important information. All the information they require is contained within a file of data. Students can also refer to the scale model and search for clues. The worksheet also serves as their technical note, on which they will be assessed, to be completed during the lab session (3 hours) and handed to the demonstrator at the end of the session before they leave.

Initial indications are that students are engaged and working together as a team. Some groups need a bit more encouragement to interact as a team than others. This is where

the role of the demonstrator is important to the success of the lab. The new lab is generating considerable interest and is accepted as an important element of the student's active learning experience.

When students arrive they are first given a tongue-in-cheek icebreaker to get them thinking and talking to one another. If the group appears to be rather quiet then the lab demonstrator uses the icebreaker questions to generate discussion.

The lab proper then commences with a short introductory talk either from a member of staff or a competent research student (the demonstrator). Thereafter the students will follow the instructions of the demonstrator who is there all the way through to facilitate but not to do the lab with the students. Students are encouraged to search for clues on the model and follow them up using the file of information, use white boards and mind-maps for discussion but fill in the worksheets, which represent the majority of the marks, on their own.

The plan in year 2 is to enable students to review the evidence gathered from the technical investigation, identify what violations have been committed and who was responsible under the legal framework and decide whether or not there is sufficient evidence to prosecute those parties responsible. They will then have to prepare a case for prosecution and expert witness statements using all the data gathered from the technical investigation.

### **Professional practice**

A number of experts have been approached to give keynote lectures on the following topics:

- i. Professional responsibilities
- ii. Human factors
- iii. Inherent safety
- iv. Codes and standards

These lectures have been packaged together and will be delivered to year 1 students taking the design module in the 2nd semester under the overall heading of professional practice. With the agreement of the experts, the keynote

lectures will be recorded together with audience interaction to enable them to be replayed in future years. This may then be used to produce a video package that can be used by other universities.

### Final year projects

A number of final year projects have been set up at Liverpool to develop the use of real-world accident data to reconstruct the events leading to the accident and determine the causal factors. One is looking at the effects of flight into a severe wind shear caused by micro-burst and another following a failure of the rudder actuator. Both are based on real-world accidents. It is planned to make more use of these types of forensic investigation projects in the future.

Another final year project is being used to explore the use of a machinery safeguarding demonstrator unit as part of a lab exercise or lecture demonstration. This project draws upon the demonstrator used by HSL to train HSE inspectors to recognise operator interference with machinery safeguards.

### LIBRARY RESOURCES

A number of key textbooks, reports and reference documents were reviewed as to their suitability for support material for the new risk syllabus and the development of educational material for lectures. Several copies were acquired for the library at Liverpool. The books and documents that were identified as being suitable were generally classed as recommended or background reading for students. Students were made aware of this resource in the opening lecture and encouraged to obtain a copy of the Engineering Council's more comprehensive guidelines on risk issues(6).

### PROFILE

The profile of the project has been raised through liaison with the Engineering Inter-Institutional Group (IIG), British Standards Institution (BSI), Institution of Mechanical Engineers (IMechE) Safety and Reliability

Group (SRG), Safety and Reliability Society (SARS). A seminar on 'Risk Education for Engineers' to be held in London at IMechE HQ is being planned for 2007 through the IMechE SRG.

### CONCLUDING COMMENTS

A class test in the form of a questionnaire given to new students at Liverpool at the start of year has been shown to be a reliable indicator of students' awareness of risk concepts. Comparisons over two years show similar averages. It has been used to set the appropriate level of tuition in year 1 and will be used to evaluate the success of the new syllabus in achieving the desired learning outcomes.

Risk topics have been successfully embedded in some year 1 core engineering modules at Liverpool through formal lectures, a virtual laboratory exercise and keynote lectures on professional practice. The lectures and lab are complementary, with the lab promoting experiential role-play learning.

There is already good anecdotal evidence from the project leader's attendance at a selection of the virtual lab exercises that students are beginning to seriously consider risk issues. Their answers to the key question set in the risk awareness questionnaire 'why is engineering regarded as a safety critical profession?' show that engineering students at the University of Liverpool understand to a significant extent their professional responsibilities for the safety of the public as recommended by Lord Cullen in his report on the Hatfield rail accident(7).

Further details of the project can be found in(3).

### ACKNOWLEDGEMENTS

The authors wish to thank the HSE and the University of Liverpool (Studentship Awards) for funding this work. Information and advice received from Steve Joel, Graham Norton and Dave Gregory of the HSL, Martin Key of EnSure, Liz Williams of the BSI, and Richard Taylor of the IIG is gratefully acknowledged.

## REFERENCES

1. **HSE and DETR**, 2000, '*Revitalizing Health and Safety - Strategy Statement*', HMSO OSCSG0390.
2. **Lee, J. F.**, 1999, '*Education of undergraduate engineers in risk concepts - Scoping study*', HSE Books C2.5 10/99.
3. **Schleyer, G. K., Duan, R. F., Stacey, N. and Williamson, J.**, 2006, '*Risk education in engineering - development of year one materials*', HSL internal report, <http://www.hse.gov.uk/research>.
4. **European Agency for Safety and Health at Work**, 2004, '*Mainstreaming occupational safety and health into education*', ISBN 92-9191-016-3.
5. **HSE**, 2000, '*Walkway collapse at Port Ramsgate*', ISBN 0 7176 1747 5, HSE books.
6. **Engineering Council**, 1993, '*Guidelines on Risk Issues*', ISBN 0-9516611-7-5.
7. **Hatfield derailment investigation**, 2002, '*Interim recommendations of the Investigation Board*', <http://www.hse.gov.uk/railways/hatfield.htm>.

# MACHINERY SAFETY EDUCATION AT THE UNIVERSITY OF BATH

**Martin Keay<sup>1</sup> and Linda Newnes<sup>2</sup>**

<sup>1</sup>Processing and Packaging Machinery Association, United Kingdom

<sup>2</sup>University of Bath, United Kingdom

## SUMMARY

This paper describes an approach adopted for educating students in the safe design of machinery. The background to safe design and the changes in legislation are introduced. The impact of this change of legislation in terms of complexity, the number of reference points for a designer e.g. Directives and standards, are also described. Based on this change, the paper then introduces how the Packaging, Processing and Machinery Association and the University of Bath approached the teaching and training of design engineers to be able to understand and follow guidelines on the safe design of Machinery. The steps taken and the learning process through the course development are described with the final outcome being a generic course written in conjunction with BSI British Standards on how to assist students to acquire the ability to risk assess machinery and learn about machinery design to help their design capabilities and their applicability to their industrial future.

## BACKGROUND

### Changes in Legislation

This section describes the engineering environment and the changes that have occurred leading to the need to train future engineers in understanding legislation and applying standards.

From 1974 to 1993 British engineers had the luxury of a single piece of legislation that dealt with the safety of machinery, called the Health and Safety at Work Act (HSWA) and one standard on the subject, BS 5304. However in 1993 all this changed, because of the introduction of the European Single Market.

The principle of the European Single Market is that if every country in Europe has the same

law on machinery safety; it is possible for a manufacturer to read the law in their own language and build the machine accordingly knowing that the machine will be acceptable in every other country in Europe.

When every country has the same law on a particular subject, it does not matter that the countries have different legal systems, different methods of enforcing those laws and different languages. However this does mean that every country has to give up its own existing laws and accept the new 'common' legislation in its place. The legal mechanism, which allows all the countries of Europe to share the same law, is called a Directive.

The European Commission drafts Directives and when they have been finally agreed the Directives compel each of the Governments of the European Union to introduce Regulations in their own country, which will have the effect intended by the Directive.

However in place of the single HSWA in the UK, engineers now have to deal with up to eight different pieces of legislation when designing machinery. For example:

- Cable Cars Directive.
- Classical Passenger Lifts Directive
- Electromagnetic Compatibility Directive (EMC)
- Equipment for Use in Potentially Explosive Atmospheres Directive (ATEX)
- Low Voltage Directive (LVD)
- Machinery Directive
- Pressure Equipment Directive
- Simple Pressure Vessels Directive

So most machines now have to comply with at least three Directives, the Machinery, Low Voltage and EMC Directives. They may also have to comply with the Pressure Equipment Directive if they contain pressure vessels over a certain volume and the ATEX Directive if the machine is to be used in an area where a dusty

product e.g. sugar is being handled or in a zone where a potentially explosive gas cloud could form e.g. a paint factory.

### Standards required to comply with legislation

Moreover this new legislation is much more complex than the relatively simple HSWA with detailed 'essential requirements'. However it gets worse because this new legislation does not stand alone. The essential requirements are all written in a goal setting way and to understand exactly how to comply with these Directives it is necessary to consult one, or a number of the European or International standards that have been written specially to support these Directives.

Here again there has been a huge increase in complexity with the single though fairly bulky BS 5304, being replaced by over **600** different European and International standards.

### Risk Assessment

This explosion in the amount and complexity of legislation and standards affecting machines has been compounded with another new ingredient for engineers, the need to carry out machinery risk assessment.

The new European Directives like the Machinery Directive are all risk based. What you have to do depends on the risk and it is the machine manufacturer who has to assess that risk and decide what must be done.

For instance in the Machinery Directive there is a requirement that '*moving parts of machinery must be designed built and laid out to avoid hazards or where hazards persist, fixed with guards or protective devices in such a way as to prevent all risk of contact which could lead to accident.*'<sup>1</sup> But this leaves it up to the machine designer to decide which parts will cause a hazard and which will not.

The answer to this question is risk assessment. Risk assessment is now required in almost every walk of life from taking a group

of school children on an outing to evaluating whether a murderer can be let out of prison on license and of course to evaluate a machine design.

Risk assessment sounds quite a scientific subject and there are detailed standards on risk assessment, but in most cases it describes the rather subjective and imprecise process of trying to work out what might go wrong when operating a machine, taking a party of children to the swimming pool or releasing a prisoner into the community and then trying to minimise the risk of those things going wrong.

### TRAINING IN INDUSTRY

So engineers have been faced with a mass of new legislation, a raft of complex standards and have been asked to acquire the new skill of machinery risk assessment.

Needless to say engineers in UK industry have been struggling to cope, particularly at a time when design and engineering departments have been slimmed down and training budgets have been slashed.

However the Processing and Packaging Machinery Association (PPMA) and other industry training providers have been trying to help by running a series of seminars and training courses for engineers in industry focusing particularly on:

- The detail of the new legislation
- The detail of the European and International standards that support the legislation
- The principles of machinery risk assessment:

The PPMA courses have been running since 1992, but the number of engineers to train and the volume of new legislation and standards involved is so great that the courses are still being run in 2006.

### TRAINING IN UK UNIVERSITIES

However by 1998 it became apparent to people in the UK processing and packaging

<sup>1</sup>Machinery Directive 98/37/EC Essential Requirement 13.7

industries that newly graduated mechanical engineers also needed instruction about the Machinery Directive and its standards and machinery risk assessment, prompting people in industry to ask whether these subjects could or should be taught at University.

This stimulated the PPMA in 1998 to offer to help the University of Bath's mechanical engineering department to develop a course suitable for mechanical engineering undergraduates.

## **COURSES AT THE UNIVERSITY OF BATH**

### **Machines and Products in Society**

The University of Bath immediately appreciated the importance of teaching this subject and worked with the PPMA to develop a course based on materials developed by the PPMA for use in industry. The course, which is called '*Machines and Products in Society*,' was a twelve week optional course for 3rd and 4th year MEng students. The course was developed with the help of a grant from the UK Department of Trade and Industry under the '*Sector Challenge*' initiative.

The aim of the course was to introduce students to the wide range of legislation that affects machinery in the European Union, including the Machinery Directive, but also the legislation on manual handling, provision and use of work equipment, control of hazardous substances and machinery risk assessment.

The course was first offered in 1999 and has attracted 15-20 students each year ever since. However the feedback from students has been mixed. On the plus side two students have taken the trouble to write saying how useful the course had been in their jobs in industry, one stating that it was the only thing she had learnt in her four years at University that was immediately useful in her first job in industry and another was stimulated to pursue a career in health and safety. However the majority had problems with the course.

The course was based on material that is used regularly to good effect in industry, but very bright undergraduates struggled. On the one hand they felt that some issues were so easy

and obvious that they hardly needed to be mentioned, but on the other they struggled to use a European standard to size a machine guard. Students also struggled badly with machinery risk assessment swinging between finding it too easy and too imprecise but failing to appreciate the wide range of hazards likely to be presented by even quite a simple machine during its lifetime.

So why does the same lecture given to engineers in industry work but not work with undergraduates? The conclusion we came to was industrial experience. Engineers with even a short amount of industrial experience can relate much more easily to health and safety legislation and risk assessment, because they are much more aware of the issues and know how machines are used and abused in industry. This conclusion was borne out by the fact that students who took the course after spending a year in industry could also relate easily to the material.

### **Knowledge required to do machinery risk assessment**

We concluded that the areas of knowledge needed to carry out machinery risk assessment include the following:

#### **General Knowledge**

1. The range of hazards posed by domestic machinery
2. The range of hazards posed by industrial machinery
3. How machines can fail and how they can be misused in industry

#### **Subject Specific Knowledge**

4. The requirements of machinery legislation
5. How hazards on machines can be eliminated
6. The process of machinery risk assessment
7. How to use standards

#### **Machine Specific Knowledge**

8. How the machine works
9. How the machine is moved, used, cleaned and maintained
10. How the machine can fail or be misused

The PPMA courses which formed the basis of the material used in the first Bath course concentrated on delivering the subject specific knowledge (items 4, 5, 6 and 7). With groups of experienced engineers this worked because they had a general knowledge of hazards and failure modes of industrial equipment (items 2 and 3) whereas students had little knowledge of industrial machinery.

### BSI 'Designing Safe Machinery' Course

In 2004 BSI British Standards (BSI) embarked on a new initiative to introduce engineering undergraduates to standards. This BSI initiative was prompted by research which indicates that British industry makes little use of standards by comparison to equivalent industries in Germany, France and the USA, which is strange given that the whole idea of writing standards and working to standards in engineering started in Britain.

BSI's objective was to develop a course that would introduce undergraduate engineers to the 'safety of machinery' series of European standards, which have been written specifically to support the Machinery Directive.

Coincidentally this happened at the same time as an initiative by the Health and Safety Laboratory to develop health and safety and risk assessment education for engineering undergraduates in conjunction with the University of Liverpool.

The BSI course, which is called '*Designing Safe Machinery*' covers the same area of legislation and standards as the original Bath course, but takes a quite different approach. Whereas the original course covered several pieces of legislation regulating both the manufacture and use of machinery, but in a general way, the BSI course considers only one piece of legislation the Machinery Directive and the 'safety of machinery' series of standards.

This course aims to provide students with:

1. A working knowledge of the Machinery Directive 98/37/EC (The Supply of Machinery (Safety) Regulations 1992):
2. An understanding of the process of machinery risk assessment;

3. Familiarity with the key standards in the Safety of Machinery series;
4. A thorough understanding of the range of hazards posed by machines;
5. The ability to design a set of guards for a machine;
6. The ability to design a set of access steps for a machine;
7. The ability to complete a comprehensive risk assessment for a machine;
8. The ability to compile a technical file for a machine as required by the Machinery Directive;
9. The ability to design safe machinery.

The BSI course is essentially an extended machinery risk assessment exercise. Students are initially asked to select a machine to risk assess and then the lectures provide them with the information that they need to complete each stage of the risk assessment.

The lectures attempt to fill the knowledge gap of undergraduates who have little or no experience of industry by explaining in some detail about the wide range of ways in which machinery can potentially injure people. For instance if someone has never heard about the condition called vibration white finger they will not realise that a vibrating mechanism can cause a disabling injury.

The BSI course also recognises that you cannot carry out a meaningful risk assessment of anything if you don't fully understand it. In the case of machinery the prerequisites are the general knowledge and subject specific knowledge highlighted in clause 3 and a good knowledge of how the machine works, how it is used, how it is maintained, how it is cleaned, how it is moved and how it is likely to fail.

This is why the choice of machines to risk assess is very important. If an obscure industrial machine is chosen, which students do not understand, their chances of producing a reasonably competent risk assessment are limited, because while they will be able to work out how the machine works they may not fully understand how it is used and maintained and they will certainly not know how it fails.

For the Bath course students chose to do their risk assessments on machine tools in the mechanical engineering workshop. This had

the advantage that the students knew how they worked and what they were used for because they had used them during their first year. However this still meant they had to find out how the machines failed, how they were maintained and the typical accidents that occur on these machines in industry.

Conversations with the lab technicians helped provide a great deal of this information, but students were encouraged to use the internet to find out accident statistics to add to their information about their chosen machine.

BSI's initial purpose when developing the course was to introduce students to the concept of using standards when designing machines and so all of the students were given a set of the twelve key standards in the safety of machinery series. Students were required to use these standards in a succession of design exercises that included designing guards for a machine, selecting interlocking devices for this machine and designing access steps.

## CONCLUDING COMMENTS

So how well was the *Designing Safe Machinery* course received by the Bath students? Well at the time this paper was being written the students were sitting their exam on this course so it remains to be seen how much of the material delivered on the course was retained.

However what we can report is how the students reacted in the lectures, assignments and tutorials and this was encouraging. Students did become familiar with the process of risk assessment, learnt about a far wider range of hazards than they would have done with the previous course and were able to produce sensible designs using European standards.

## ACKNOWLEDGEMENTS

The authors wish to thank the DTI, BSI Standards, the Processing and Packaging Machinery Association and the University of Bath for funding this work. They also wish to thank Nicola Stacey from HSL, Richard Wilson from HSE, Liz Williams from BSI Standards and Ernie Jeffrey from EN-Sure Consultants for their advice and support.

## REFERENCE

**Machinery Directive 98/37/EC** published in the UK as *The Supply of Machinery (Safety) Regulations 1992*, by The Stationery Office

## INTELLECTUAL PROPERTY TOPICS IN OPEN UNIVERSITY DISTANCE-TAUGHT COURSES

**Peter R Lewis and Michael E Fitzpatrick**

The Open University, United Kingdom

**Keywords:** forensic, engineering, case studies,

### ABSTRACT

*Patents lie at the heart of engineering as a permanent and ongoing record of invention. We have taught the subject for about 5 years in both UG and PG courses, written from scratch owing to the absence of textbooks aimed specifically at engineers. Most practising engineers develop patent skills on the job rather than through conventional courses. But there is a need to present such courses as early as possible in the engineering curriculum, so that graduates have a flying start in their first employment.*

### INTRODUCTION

The impetus for developing IP courses in the OU came when students at a weekend school in the mid-1990s enquired about the subject. The students in question were a cohort from Eire, working in new industries established there using EU funds. The companies included computer manufacturers as well as medical device makers. Some of the group were themselves patentees, and a smaller number pursuing alleged infringers.

At that time, one of us (PRL) was involved in a number of on-going court actions, and had some experience of providing expert evidence in *Black & Decker-v-Flymo*, a case heard in the High Court in 1989/90(1). We were thus in the position to provide some case studies from personal experience, as well as others which had been essential reading in preparing for trial. Patent actions are very revealing for the nature of invention, and the way it is controlled by legal requirements. In any patent litigation, the patents-in-suit will be dissected both by lawyers and engineers in infinite detail, especially for their proximity to the prior art and hence the level of inventive skill. During the late 1990's we became involved with London Metropolitan University in developing an Integrated Graduate

Development Scheme (IGDS) in polymer technology. It was an ideal route to developing a new Forensic Engineering course, which would include a large slice of IP.

Concurrently the Faculty of Technology at the OU was developing a new Level 1 (first-year-equivalent) engineering course, and hence there was an opportunity to re-use the case studies, with appropriate wrap-around teaching material, in this course as well. The Level 1 course was thus able to engage students with technical documentation such as patents and Standards at an early point in their studies.

### CASE STUDIES

Several case studies of the actions in which PRL had been involved were incorporated into these courses. A very recent case introduced the subject in the PG course (*Schneider-v-Taylor*, Patents County Court, 1996), an action involving wheelie bins. The first invention was a German design patent from 1986, (**figure 1**). The key inventive step was the design of the lip of the bin(2). The strength of this part is critical to its function, since the whole bin must be lifted by a comb bar on the back of a refuse lorry. The lip must be strong to resist the load of a full bin, and the German patentees had addressed the problem by reinforcing the lip with a steel bar (**figure 1**). Shortly after, Schneider patented a design where the entire lip was moulded in HDPE plastic. The lip was reinforced by designing in numerous ribs (**figure 2**), the key technical effect claimed in the patent(3). It was clear from the description that the bin claimed was made in plastic rather than metal. The product was introduced into the UK shortly after, and sold well as local authorities adopted the system.

In the 1980's, an entrepreneurial company in the Midlands (EH Taylor & Sons Ltd) spotted a

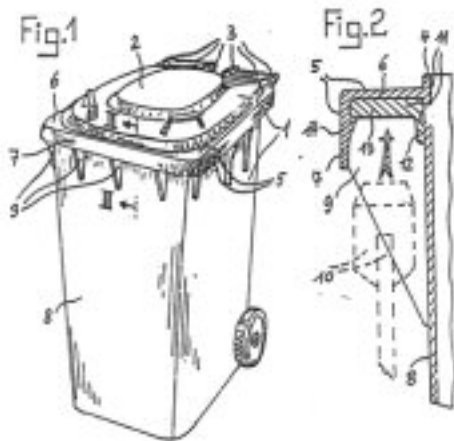


Figure 1: Original design of wheelie bin

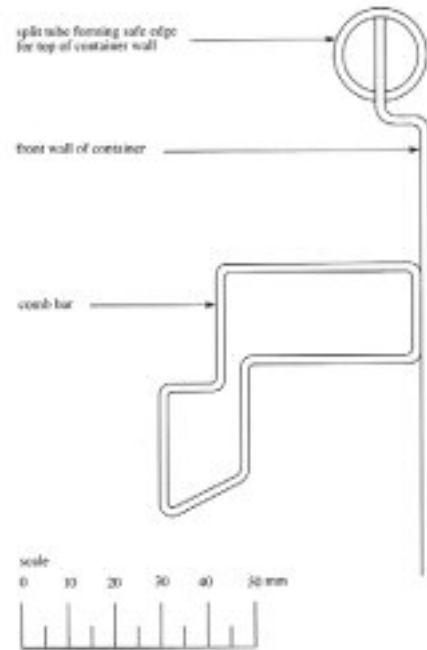


Figure 3: Taylor lifting lip section

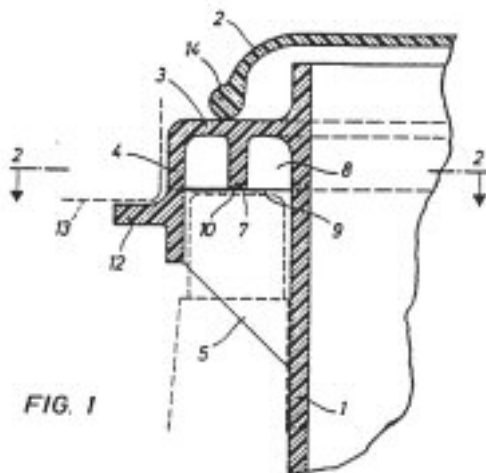


Figure 2: Schneider lifting lip section

gap in the market, especially for the large 1100 litre bins. The market preferred incombustible bins to discourage vandalism, and a lifting lip could be made which was quite different to that claimed by Schneider (**figure 3**). The case was settled by the court ruling that Schneider was valid, but not infringed. Taylors have gone on to capture about 40% of the market in large bins.

## TEACHING AIMS

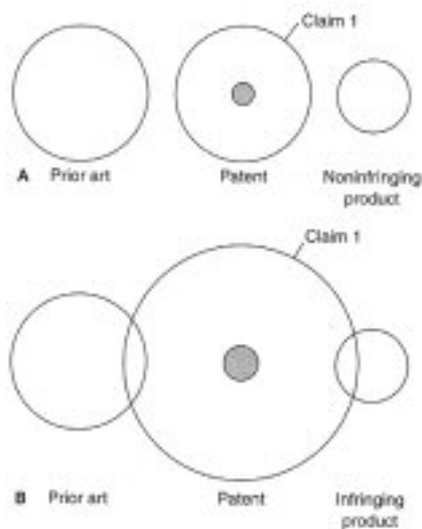
The case study teaches several basic skills:

1. how to read a patent

2. how to interpret the claims in the light of the description of a specific embodiment
3. ways in which a new product can avoid infringement
4. how to explore the prior art
5. how different materials allow for different design solutions

The more advanced aims (2, 4) are restricted to the PG course. At UG level, 1, 3 and 5 are most important.

Other case studies add extra skills. Thus the more complex case Black & Decker-v-Flymo (lawnmowers) dealt with the background to infringement actions including the classic Gillette case from 1905. If a designer can show that each and every step he took in producing an allegedly infringing product was obvious, then there is no case to answer(4). The same Black & Decker-v-Flymo case also highlighted some important precedents, such as Catnic(5), Windsurfer and Workmate. The underlying principles involve simple mechanical concepts, such as levers, screws and load distribution via a monocoque or spaceframe. Materials are usually omitted from patent specifications, but it is often clear that particular materials are optimal in some designs (such as the wheelie bin). Avoidance can involve switching from one material to another, so changing the manufacturing method and often thus avoiding



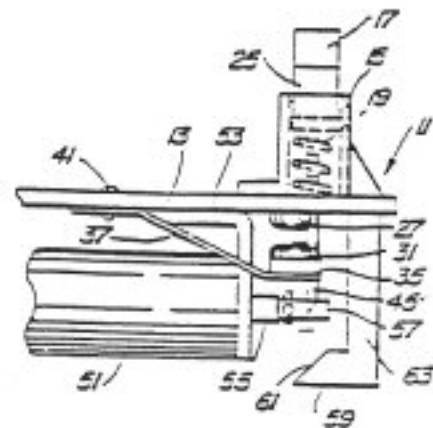
**Figure 4: Patentee's dilemma**

specific design elements claimed in the original patent. Thus the steel wheelie bin avoided infringement because it did not possess any ribs within the lifting lip, an essential element claimed by Schneider.

The lawnmower action involved highlighting the prior art as a defence against infringement. The patent-in-suit was very close to the prior art, and the claimant needed to interpret his Claim 1 very widely to catch the alleged infringers. By so doing, it is then possible to show that the same interpretation can also catch the prior art. If this happens the patent must be invalid for obviousness, and just this happened in the action (**figure 4**). The explanatory diagram illustrates the patentees dilemma of how he wishes to draw his boundaries. Draw them wide and you catch the prior art, but if too narrow, the alleged infringer can escape. The case was also of interest for setting a precedent on discovery of evidence(6). This case study has the additional value of teaching UG students about the design of structures, and the technical terminology (monocoque, space-frame etc) associated with the rigorous description of a design.

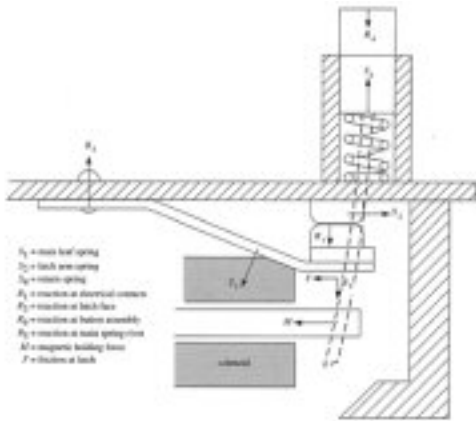
## ELECTROMECHANICAL PATENTS

Another recent case demonstrates the import-

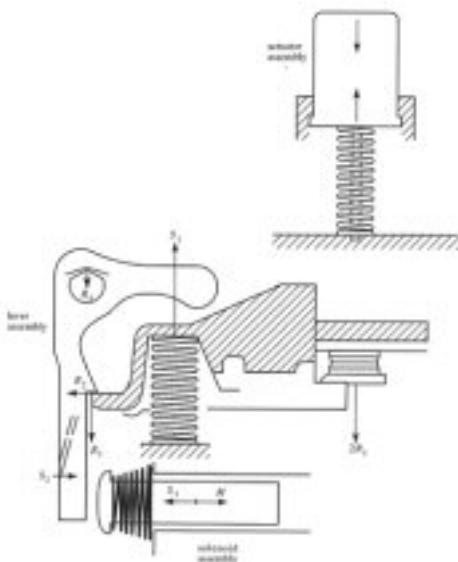


**Figure 5: Westinghouse RCD**

ance of the meaning of technical terms in claims. It concerned residual current devices (RCDs). They protect the user against accidental electrocution by detecting small changes in the live circuit. Although the Edison fuse will cut a live circuit when overloaded, it takes considerable time, and certainly not enough time to prevent electrocution. The problem of devising a reliable fuse can be dated to the first circuit breakers, but they protect equipment rather than lives owing to a long reaction time. The most important invention in this area was the Westinghouse RCD, patented in 1976. The preferred embodiment comprised a system of linked leaf springs held in metastable equilibrium by a solenoid powered by the mains supply (**figure 5**). A simplified version of the patent diagram is shown in **figure 6**. The solenoid is triggered by a leak from live or neutral and the response time is lower than the threshold to cause death or serious injury. The device is sold in the UK as the Powerbreaker, but Volex introduced a similar device for plugs in the 1990s known as the Protector. It had been designed by PDL, a New Zealand company. The device acted in a similar way to the Powerbreaker, but did it infringe the Westinghouse patent? Claim 1 of the patent-in-suit talked about 'linked' levers and springs, specifying continuous physical contact of the key components. But the Protector was based on a slightly different concept. It used coil springs and rigid levers, and worked in the same way, but with one exception. The solenoid was not in direct physical contact with the set of levers, and acted by impact when triggered by a drop in the mains voltage (**figure 7**). The mechanism



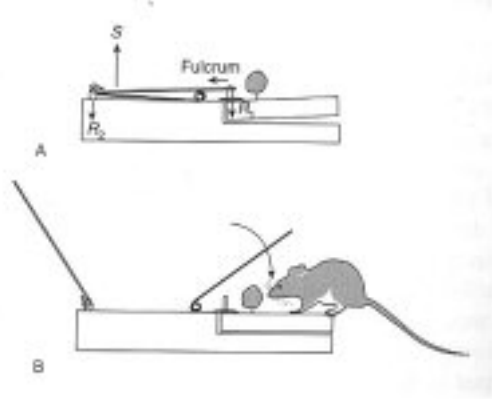
**Figure 6: Simplified section of Westinghouse RCD**



**Figure 7: Protector RCD**

bears comparison with a simple mousetrap (**Figure 8**).

At trial, the Westinghouse patent was found valid but not infringed by the Protector. Competition between the two devices has lowered prices to the benefit of the consumer, an important aspect for safety devices in general. So what lessons can be taught about the action? It re-emphasised the key nature of the words of a claim when interpreted in the light of the specification. Claim 1 of any patent



**Figure 8: Little Nipper**

is always couched in the most general terms, quite deliberately so as to catch potential infringers. But if an improvement is made to the working mechanism, then the device is entitled to further protection by a new patent. In this case, there was evidence that the device worked very rapidly (30 ms reaction time), and gave good protection against mains leakage.

But above all, it is vital to evaluate the way a particular device works in practice, so as to have the clearest possible picture of the technical effect, and the boundaries of the patent when compared with similar devices. A final puzzle remains: why did it take so long to invent such a basic safety device? Edison's fuse is now about 130 years old but is still used widely in consumer products. RCD's have spread fast since invention, but are still relatively large compared with a cartridge fuse. On the other hand they give the user a far higher degree of protection. They are now mandatory in consumer supply boards for new dwellings.

Because definition of terms is important, PRL initiated development of a new Materials Technology dictionary with Chambers after the Black & Decker-v-Flymo case(7). It was produced by a team of OU colleagues, and remains the only specialist technical dictionary from Chambers still in print. Our new definitions and explanatory panels have been used in the parent dictionary(8).

**Design Protection**

Other forms of intellectual property important for engineers include copyright, design right, and

registered design as well as trademarks and confidential information. *Interlego-v-Tyco* is one case of abiding interest for the attempt to extend copyright protection to product design. Interlego, the Danish based manufacturer of toy interlocking bricks, tried to prevent Tyco making similar bricks by claiming copyright infringement. The value of copyright lies in the extended period of protection, 70 years after the death of the originator, compared with only 20 years for patent protection. The situation seemed to violate the supremacy of patents, and Interlego's case was rejected by the Privy Council(9). A similar case involved British Leyland, who claimed copyright in their engineering drawings of exhaust pipe systems, preventing small manufacturers from supplying cheaper copies to the market. This case too was rejected(10), and the new Act of 1988 replaced copyright in engineering drawings by 'design right', an unregistered right over design features in a product. But most important, all 'must-fit' or 'must-match' parts are excluded from protection, so allowing competition in spare parts.

We teach our students to make full use of the many public databases of IP, as a necessary way of keeping in touch with the state-of-the-art.

## UG COURSE

Engineering principles underlying the key patents are explained in greater detail in our undergraduate course, and a key part of the assessment requires students to engage with relatively simple patents to extract key information. Students are aware that they will be discussing practical and real issues. It also allows embedding of IP concepts at an early stage in the curriculum. The Level 1 course T173 has registered over 5000 students since 2001; the postgraduate course T839 has registered over 400.

## CONCLUSIONS

Feedback on both courses is good, and there may be enough interest and demand to create a new course devoted solely to IP. For example, engineering and science research students receive very little training in this subject. Most grant funding bodies now ask for IP awareness when making awards. It is also written into the

new Engineering Council guidelines for training professional engineers (UK-SPEC). Such a venture would have to widen the scope by discussing chemical and biological IP, as well as software and business systems patents. Owing to the rapidly changing state of technology, there are problems of interpretation of the law. Students should be aware of possible future litigation, and be prepared for any new legislation. Such a course should aim to provide basic skills in reading and assessing patents in many different fields. Some of our case studies have been presented to a wider audience in a recent book(13).

## ACKNOWLEDGEMENTS

The Open University for permission to reproduce some of the diagrams taken from T839, Forensic Engineering, and EPSRC for funding original and further development of the post-graduate courses. We acknowledge the contributions of our colleagues at London Metropolitan University.

## REFERENCES

1. *Intellectual Property Decisions*, 14(5), 2, (1991).
2. Ger 7611603 (1975)
3. GB 1 588 932, (1976)
4. Gillette Safety Razor Co-v-Anglo American Trading Co Ltd, *Reports of Patent Cases*(RPC), 30, 465 (1913).
5. Catnic Components-v-Hill & Smith, *RPC*, 183 (1982).
6. *All England Law Reports*, 3, 158 (1991).
7. **Walker, P.** (Ed), *Chambers Dictionary of Materials Science and Technology* (1994).
8. **Walker, P.** (Ed), *Chambers Dictionary of Science and Technology*.
9. *Interlego-v-Tyco*, RPC 343 (1988).
10. *BL Components-v-Armstrong*, RPC 279 (1986).
11. **Lewis, P. R.** (Chair), *T839 Forensic Engineering*, OU (2000).
12. **Fitzpatrick, M. E.** (Chair), *T173 Engineering the Future*, OU (2000).
13. **Lewis, P. R., Reynolds, K. and Gagg, C.,** *Forensic Materials Engineering*, CRC Press (2003).

## EMBEDDING EXPERIENTIAL LEARNING IN ENGINEERING EDUCATION

E. M. Rodriguez-Falcon, M. J. Carré and J. R. Yates

The University of Sheffield, United Kingdom

### ABSTRACT

*The Department of Mechanical Engineering at the University of Sheffield has developed a Motorsports Engineering Management programme that incorporates a variety of teaching and learning techniques. This approach fosters creativity and successfully enables technical and academic skill development.*

*The degree programme provides students with the unique opportunity of actively getting involved in motorsports at a practical level, as well as developing and managing a motorsports company by the end of the programme. At the same time they learn and apply the expected engineering principles of MEng level mechanical engineering programmes. Experiential and reflective learning are at the heart of the curriculum.*

### INTRODUCTION

Providing students with the right skills to become successful in an increasingly competitive world, whilst delivering an exciting and worthwhile learning experience are challenges facing all higher education institutions. It is well accepted that engineering students not only require sound technical training but also a good understanding of management issues, and an outstanding level of transferable skills.

In 1992 Mendus(1) argued that students should be presented with different and competing traditions in order to facilitate critical creation as well as critical discovery. Kolb in 1993(2) explained the need for experiential learning. He suggested that within experiential learning the student moves from actor to observer and from specific involvement to general analytic detachment. In other words, experiential learning goes hand in hand with reflective learning.

Kolb further defines experiential learning as a continuous process grounded in experience,

where learning is developed through adaptation and problem solving activity. Hence, this type of learning is a process of knowledge creation rather than an activity of memorizing information. Experiential learning according to Kolb is 'the process whereby knowledge is created by transformation of experience'.

However, experiential learning could arguably be meaningless without a process of reflection. Barnett(3) suggests that students should be reflective practitioners, where sufficient self reflection and critical self-evaluation enable students to develop valid knowledge that goes beyond excitement and vain interest in the subject.

This case study provides an insight into a degree programme developed at the Department of Mechanical Engineering at the University of Sheffield where experiential learning is at the heart of the programme.

This paper presents the methodologies applied, the effects of experiential learning and results obtained after two years of running the programme. Student's understanding of experiential learning are explored as well as the benefits and relevance. Finally, the future challenges are discussed.

### PROGRAMME BACKGROUND

The Motorsports Engineering Management programme was conceived in 2002, and recruited its first intake in 2004. At the start of the programme, the rationale for the development of a non-typical engineering degree was that the number of students specialising in Motorsports Engineering and Management in the UK had substantially grown over the last few years. Surveys carried out in the department showed that other Colleges and Universities in the UK were already addressing the need to produce motorsports courses. The demand for these

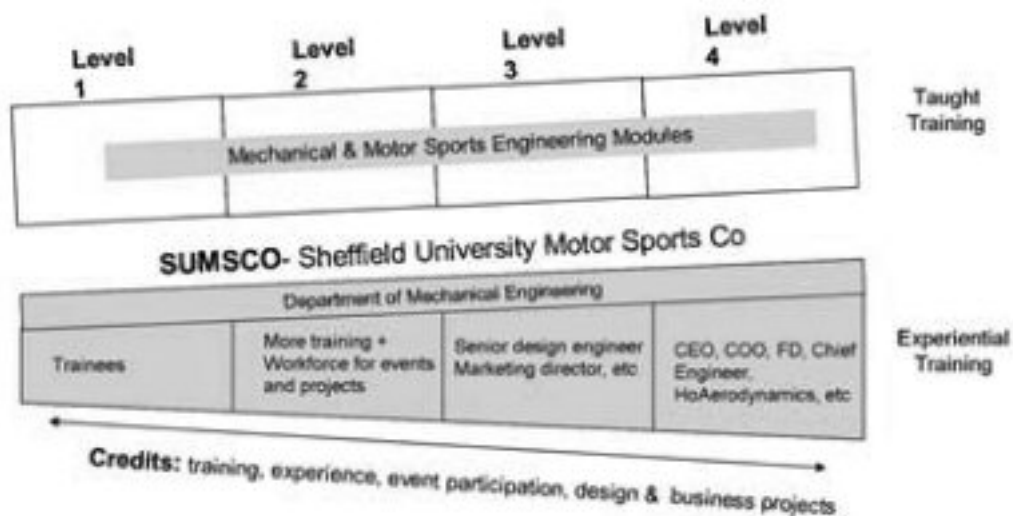


Figure 1: Motorsports degree outline

courses is growing such that by 2006 over 11 HEIs will offer courses linked to motorsports.

Further, another important factor was that many students who undertook Mechanical Engineering degrees saw their future careers in management roles, often within the motorsports industry, rather than in specialised technical engineering roles.

This course aimed to respond to this current trend. Students are provided with mechanical engineering skills which are applicable to the motorsports industry and with the necessary entrepreneurial skills in order to run their own motor sports company.

Since 1992 undergraduate curricula in the UK has become modular, with more than 50% of universities expanding or introducing a common curriculum over the last thirteen years. Jackson(4) explains that although there has been a high resistance to modularity within the academic community there is no question that modularity is here to stay.

The programme under study is no exception; however, 16% of the programme is experiential rather than didactic. During the first two years, students are trained in motorsports skills at approved motorsports schools and associations (see programme outline in **figure 1**).

The reasoning behind this is that in order to motivate students and excite them, the course should provide practical experience that would benefit the students' learning process.

During the course of their degree, students form a motorsports company that has been set up in the department to run alongside the programme as a way to provide a practical understanding of motorsports while developing entrepreneurial skills in students.

In the first two years, students get the opportunity to obtain a motorsports driving licence, and gain experience in motorsports related activities. In the third year, as part of a group project the students are able to design racing car components and develop racing cars. In the final year, students contribute to motorsports events, helping in the development, organisation and running of the event, or alternatively being part of a consultancy team, which will provide advice to other motorsports teams.

Students completing the programme will have further developed their mechanical engineering knowledge but also gained knowledge of the essential aspects of motorsports engineering management. The MEng degree has been designed to fully satisfy the academic and practical requirements for achieving Chartered Engineer status. In addition, accreditation by

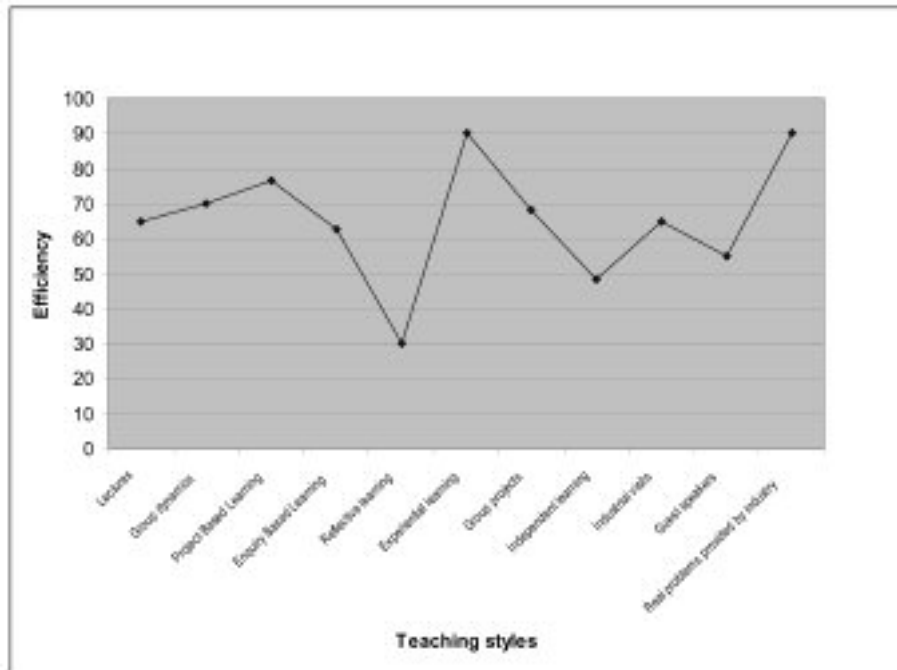


Figure 2: Teaching style efficiency: A students' viewpoint

the Institute of Mechanical Engineers has been successfully received.

### INVESTIGATION INTO EXPERIENTIAL LEARNING EFFECTIVENESS

In order to evaluate the effectiveness of experiential learning as an integral part of the course structure a small scale investigation was conducted. All motorsports students (5 second year and 9 first years) were surveyed and a single interview was conducted to explore in more depth students' perception and understanding of experiential learning.

Students were asked in the survey about their understanding of experiential learning, its effectiveness compared to other learning techniques, its value and benefits and also its relevance to their decision to do this particular degree programme.

Students' definitions of experiential learning included the following:

'It is learning from actually doing the work and seeing how it's done instead of listening to someone talk about it.'

'Experiential learning is the way to learn by your own experience and not by theory.'

'Experiential learning is learning from actual situations in an activity, or learning through a practical approach.'

Students' perception clearly suggests that their understanding of experiential learning is not far from Kolb's definition 'the process whereby knowledge is created by transformation of experience'(2). However, there is the counter argument that no theory at all can lead to maladaptive learning.

The study also showed the value of experiential learning according to students' view points. A series of learning methods were presented to students who then attached a percentage value to each one of them. **Figure 2** shows that students find experiential learning as a top teaching method, giving this learning technique 90% efficiency compared with 30% for reflective learning. The latter of course is a disturbing figure as reflective learning must go hand in hand with experiential learning according to Kolb. A high percentage of the respondents said that they did not understand reflective learning enough to comment on it. This suggests that this end of the learning process has not been closely tightened and therefore, learning outcomes could arguably not have been met.

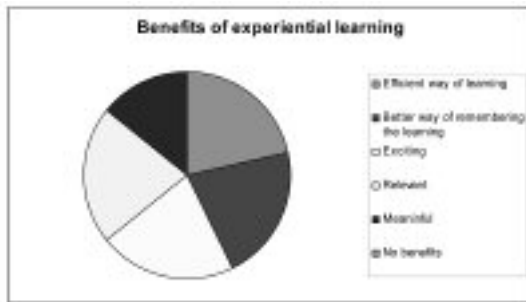


Figure 3: Benefits of experiential learning

However, it is undeniable that students view experiential learning as a real and valuable way of learning. Students said in the questionnaire that experiential learning gives meaning and excitement to the learning experience (see **figure 3**). In their appreciation of experiential learning they seemed to link effective problem solving, good understanding of subject matter and good career prospects to this type of learning.

Relevant quotes included:

‘Experiential learning is very important as it enhances the learning experience and hopefully makes it more interesting.’

‘It takes you into a real life situation where you can learn by actually carrying tasks out’.

‘It makes a huge difference in providing students with a realistic view of what they learn in lectures is actually applied and how. Without this students lose the will to learn as they don’t know why they should be learning it.’

‘It is very important because it gives students the capability to acquire skills that can’t be acquired in any other way, and that’s an advantage upon other students and so better chances to get a better job in the future.’

‘Because we get a hands on approach, we have a better understanding of a problem we are facing. We understand its direct influences; therefore, we have a better chance of solving the problem efficiently.’

Clearly, practical participation or experiential learning has added great value to education. This learning technique provides an alternative

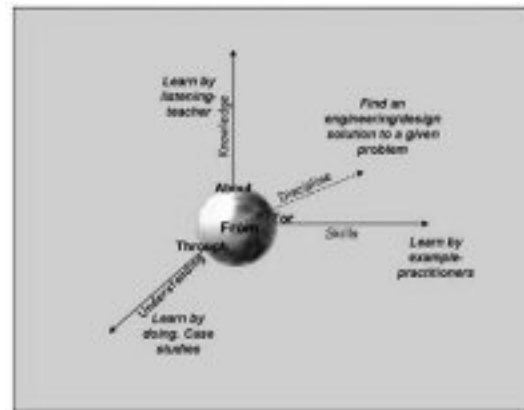


Figure 4: White Rose Centre for Enterprise learning model

to narrative education by making knowledge relevant and exciting to students(5).

## ENTERPRISE IN EDUCATION

Handscombe *et al.*(6) call the area of enterprise the fourth dimension of education. The argument develops that enterprise is not just a business subject, but rather, a different approach to learning achieved by putting greater emphasis on the integration of enterprise skills into the curriculum and by presenting enterprise programmes as an opportunity to enhance skills and knowledge.

This broad focus sees enterprise as an empowering and powerful set of personal attributes and competencies that can be employed in any number of settings(6). These settings include commercial ones but are not limited to them specifically.

Hence, students need to be taught about the topic: to learn relevant knowledge and theoretical frameworks. They need to be taught for the topic such that they develop skills that they can apply in practice and they need a learning experience (education through enterprise in this case) that gives them an understanding of the interpersonal and emotional issues. The result, the learning of the topic in the context of and from the core of the student’s chosen subject, has added a fourth dimension, what Handscombe *et al.* term in their case, ‘enterprise from discipline’.

This indicates that the learning needs to begin where the student is and in the context of the student's chosen subject as illustrated in **figure 4**.

### **INVOLVEMENT OF INDUSTRY**

This approach to curriculum development has become highly important to achieve the requirements of yet another big stakeholder; employers. In fact, employers are increasingly becoming more involved in the design and delivery of curriculum. In this particular case, the local motor club and the motorsports association have been closely involved in this degree since its conception. Undoubtedly there are benefits; potential employers getting involved so early, providing knowledge, resources and opportunities is perhaps an emerging way of teaching.

In addition, the experiential learning opportunity this degree provides gives real meaning to the interactionist perspective. The opportunities for the teacher and the student to interact, to create ad-hoc learning, to develop new and innovative ways of learning are numerous. Teacher and students spend long hours in the field; both learning, both teaching. The syllabus is flexible to some extent and as a consequence the student and the teacher are able to develop the learning outcomes together. The outside organisations provide the means for the teacher and the student to experience the learning in this way. In line with the literature, the ultimate learning experience is the assessment whereby the student is assessed by reflecting on their experiences. As mentioned previously to have been clearly identified by students.

### **CURRENT STATUS**

The programme has been running for two years. The first group of students have become licensed motorsports marshals, have marshalled at sixteen events, on average, and will very soon be licensed competitors. On the academic side their results have been more than satisfactory, and their feedback on the course is exceptional. According to the study carried out 84% of the current motorsports students said that they would have not done

this degree programme if it had not included experiential learning.

In terms of attracting students, the second cohort of students was double the first, and obviously all have joined the motorsports company that runs alongside the programme. The company is already showing signs of economic growth thanks to students' commitment and enthusiasm.

### **CONCLUSIONS AND FINAL NOTE**

It is the experiential side of the programme that has made this degree course original and truly innovative. This has involved blending together some of the educational approaches that make learning more effective and fun, such as problem based learning, experiential learning, and reflective learning. Further, this learning has been made relevant to students by bringing real case studies into the classroom and by taking students out into the real world.

However, although the programme has proved to be greatly successful and marketable; it has also proved to be rather expensive due to the experiential side of the programme. The Department therefore is faced with the challenge of making this course profitable enough so that the innovative side of it remains, and the course continues to be a success. This challenge has been taken into account, and even students are aware of it. SUMSCO, therefore, has the additional aim of helping sustain the course so that our students continue to be educated in an exciting and proactive manner.

The main challenge, however, is making experiential learning a true educational experience not just a fun way of passing the time.

Kolb(2) covered all these shortcomings comprehensively in his observation that: 'When viewed from the perspective of experiential learning, the tendency to define learning in terms of outcomes can become a definition of non-learning, in the process sense that the failure to modify ideas and habits as a result of experience is maladaptive.'

And this is our main challenge.

## REFERENCES

1. **Mendus, S.**, 1992, '*All the King's Horses and all the King's Men: Justifying Higher Education*', *Journal of Philosophy of Education*, Vol. 26, 173-182
2. **Kolb, D. A.**, 1993, '*The Process of Experiential Learning*', in: M. Thorpe, R. Edwards & A. Hanson (Eds), *Culture and Processes of Adult Learning*, 138-156
3. **Barnett, R.**, 1990, *The Idea of Higher Education*, Buckingham Open University Press
4. **Jackson, N.**, 1995, *HEQC Update*, No.8, i-iv
5. **Freire, P.**, 1972, *Pedagogy of the Oppressed*, Penguin, London, 45-59
6. **Handsome, R. D., Rodriguez-Falcon, E. M. and Patterson, E. A.**, 2005, '*Embedded Enterprise Learning: About, Through, For and From*', Proceedings of the ASME International Mechanical Engineering Congress, USA
7. **Kearney, P.**, 1996, *The Relationship between Developing of the Key Competencies in Students and Developing of the Enterprising Student*, Paper commissioned by Department of Employment, Education, Training and Youth Affairs, Canberra, Australia